

## **Kunststoff PVDF**

**Verschraubungen**









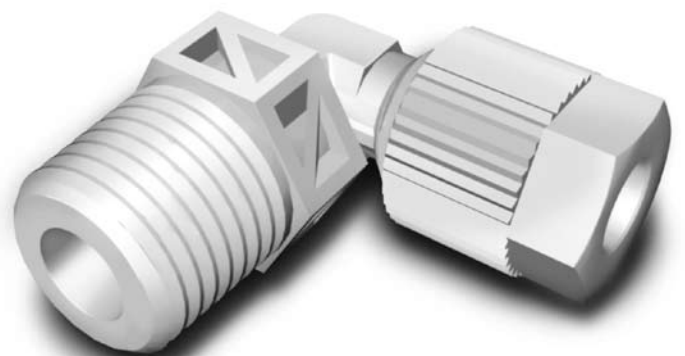















## **Plastique PVDF**

**Raccords**

## **Plastic PVDF**

**Unions**



	Seite/Page/Page		Seite/Page/Page		Seite/Page/Page
Klemmring Bague de serrage Compression ferrule	<b>2.4</b>  <b>SO 20001</b>	Verbindungsrippel Pièce folle Tube stub	<b>2.13</b>  <b>SO 21300</b>	Einstellwinkel Coude orientable Adjustable elbow union	<b>2.21</b>  <b>SO 22621</b>
Abschlusszapfen Bouchon d'arrêt Plug	<b>2.4</b>  <b>SO 20002</b>	Gerade Schottverschraubung Union double pour passage de cloison Panel mount union	<b>2.14</b>  <b>SO 21521</b>	Winkelschottverschraubung Coude pour passage cloison Panel mount elbow union	<b>2.21</b>  <b>SO 22721</b>
Rändelmutter Ecroû moleté Knurled nut	<b>2.5</b>  <b>SO 20020</b>	Einstellnippel Union orientable mâle Adjustable male adapter	<b>2.15</b>  <b>SO 21600</b>	T-Verschraubung Té Tee union	<b>2.22</b>  <b>SO 23021</b>
Übergangsmuffe Adaptateur femelle Female adaptor	<b>2.6</b>  <b>SO 20030</b>	Einstellnippel Union orientable mâle Adjustable male adaptor	<b>2.17</b>  <b>SO 21624 OR</b>	T-Verschraubung Té Tee union	<b>2.23</b>  <b>SO 23221</b>
Schlauchtülle Douille cannelée pour tuyau Hose nozzle	<b>2.7</b>  <b>SO 20503</b>	Reduktionsverschraubungen Réduction Reduced union	<b>2.18</b>  <b>SO 21821</b>	Einstell-T Té orientable Adjustable tee union	<b>2.24</b>  <b>SO 23621</b>
Gerade Verschraubung Union double Straight union	<b>2.7</b>  <b>SO 21021</b>	Winkelverschraubung Coude Elbow union	<b>2.18</b>  <b>SO 22021</b>	T-Einschraubverschraubung Té mâle Male adaptor tee union	<b>2.25</b>  <b>SO 23721</b>
Gerade Einschraubverschraubung Union mâle Male adaptor union	<b>2.8</b>  <b>SO 21121</b>	Winkelverschraubung Coude Elbow union	<b>2.19</b>  <b>SO 22221</b>	Reduziermuffe Réduction femelle-femelle Female reduction socket	<b>2.26</b>  <b>SO 20031</b>
Gerade Aufschraubverschraubung Union simple femelle Female adaptor union	<b>2.12</b>  <b>SO 21221</b>	Winkel-Einschraubverschraubung Coude mâle Male adaptor elbow union	<b>2.20</b>  <b>SO 22421</b>	Reduziernippel Réduction femelle-mâle Male reduction nipple	<b>2.26</b>  <b>SO 20041</b>

**Seite/Page/Page**

**2.27**

Sechskant-Verschlussschraube  
Bouchon mâle à 6 pans  
Male hexagon plug



**SO 20371**

**2.27**

Einschraubtülle  
Douille cannelée à visser  
Male adaptor hose nozzle



**SO 20511**

**2.28**

Doppelnippel konisch-konisch  
Mamelon mâle-mâle conique-conique  
Male adaptor tapered-tapered



**SO 21109**

**Sonderausführungen:**

**Exécution en option:**

**Optional Services:**



Spezialreinigung - entfettet  
Traitement spécial - sans silicone  
Special treatment - degreased



Vorbeschichtete Gewinde mit Loctite 5061  
Filetages pré enduits avec Loctite 5061  
Pre-coated threads with Loctite 5061



Vorbeschichtete Gewinde PTFE-Band umwickelt  
Filetages pré enduits avec ruban en PTFE  
Pre-coated threads with PTFE-tape

Sonderausführung für Adapter siehe  
Kapitel 9

Exécution en option pour Adaptateurs voir  
chapitre 9

Option Services for Adaptors see chapter 9

## Kunststoff PVDF

## Plastique PVDF

## Plastic PVDF

### Eigenschaften, Besonderheiten

- einfache, schnelle Montage
- grosse Sortimentsvielfalt
- höchste Chemikalienbeständigkeit

### Funktionsprinzip

siehe Anhang

### Anwendung

Zur Verbindung von Kunststoffrohren und Schläuchen, besonders bei aggressiven Medien oder Umgebungen.

### Werkstoff

Polyvinylidenfluorid PVDF zeichnet sich aus durch hohe Beständigkeit insbesondere gegen korrodierende Agentien und aliphatische, aromatische und chlorierte Kohlenwasserstoffe, Carbonsäuren, Alkohole, Mercaptane. Nicht widerstandsfähig ist PVDF gegen stark basische Amine, Alkalien und Alkalimetalle.

### Beständigkeitsliste

Detaillierte Angaben enthält die Beständigkeitsliste im Anhang. Diese Angaben erheben keinen Anspruch auf Vollständigkeit. Nichtnennung von Chemikalien und Temperaturen ist nicht gleichbedeutend mit einer Aussage über die Einsatzfähigkeit. Die Eignung im Einzelfall ist unter Praxisbedingungen zu prüfen.

### Nenndruck PN

10 bar bei 23°C (3fache Sicherheit)

### Temperaturbereich

-40°C bis +120°C bei Verschraubungen  
-40°C bis +80°C bei Ventilen

### Anzuschliessende Rohre

Toleranzhaltige Rohre und Schläuche mit sauberer Oberfläche und gleichmässiger Wandung. Siehe auch Kapitel Rohre und Schläuche.

### FDA-Konformität

Polyvinylidenfluorid (PVDF) entspricht der CFR\* 21, § 177.2510 der FDA (Food and Drug Administration, USA) und kann für den Einsatz im Kontakt mit Lebensmittel verwendet werden.

\*Code of Federal Regulations

### Généralités

- montage facile et rapide
- gamme complète
- excellente résistance chimique

### Principe de fonctionnement

voir annexe

### Application

Pour l'assemblage de tubes et tuyaux en matières plastique dans les domaines les plus importants.

### Matériau

Fluorure de polyvinylidène PVDF est résistant aux agents corrosifs et aux hydrocarbures aliphatiques, aromatiques et chlorés, aux acides carboxyliques, aux alcools et aux hydrocarbures mercaptanes. Le PVDF ne résiste pas aux amines fortement basiques, aux alcalis et aux métaux alcalins.

### Les résistances chimiques

Les tableaux dans l'annexe donnent les détails de sa résistance chimique. Ces données ne sont pas limitatives. L'omission, dans les tableaux, de certains produits chimiques et de certaines températures n'indique rien sur la possibilité ou l'impossibilité d'une utilisation. Dans chaque cas, il est recommandé de procéder à des vérifications préalables.

### Pression nominale PN

10 bar à 23°C (facteur de sécurité 3)

### Plage de température admissible

-40°C à +120°C pour raccords  
-40°C à +80°C pour robinets

### Tubes à utiliser

Tubes et tuyaux flexibles respectant les tolérances avec surface propre et d'épaisseur de paroi régulière. Voir aussi chapitre tubes et tuyaux.

### Conformité FDA

Fluorure de polyvinylidène (PVDF) est en conformité avec le CFR\* 21, § 177.2510 de la FDA (Food and Drug Administration, USA) et peut être utilisé en contact avec aliments.

\*Code of Federal Regulations

### Characteristics, specialities

- easy and fast to install
- extensive range
- high resistance to chemicals

### Operating principle

see appendix

### Application

Primary designed for connecting in important fields of application.

### Material

Polyvinylidene fluoride PVDF is especially resistant to corrosives and aliphatic, aromatic and chlorinated hydrocarbons, carboxylic acids, alcohol and mercaptanes hydrocarbons. PVDF is not resistant to alkaline amines, alkalis and alkaline metals.

### Resistance to chemicals

For details regarding resistance to chemicals see appendix. This information does not claim to be complete. The absence of information referring to chemicals and temperatures is not to be regarded as a statement of their suitability. This should be tested in each individual case under operational conditions.

### Nominal pressure PN

10 bar at 23°C (safety factor of 3)

### Temperature range

-40°C to +120°C for unions  
-40°C to +80°C for valves

### Tubes to use

Tolerance complying tubes and hoses with clean surface and uniform wall thickness. See also chapter tubes and hoses.

### FDA-Compliance

Polyvinylidene fluoride complies with the CFR\* 21, § 177.2510 of FDA (Food and Drug Administration, USA) and can be used in contact with food.

\*Code of Federal Regulations

### Druckauswertungsgrad in % des PN

### Coefficient de pression de service admissible en % de PN

### Pressure coefficient % of PN

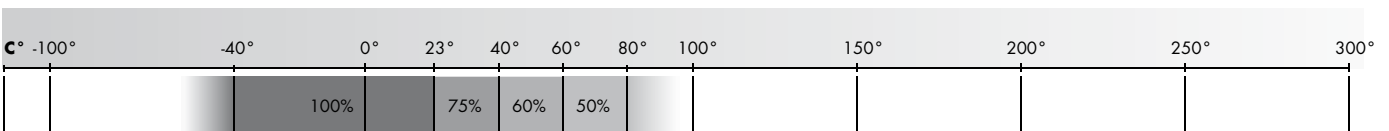

**Klemmring**  
**Bague de serrage**  
**Compression ferrule**

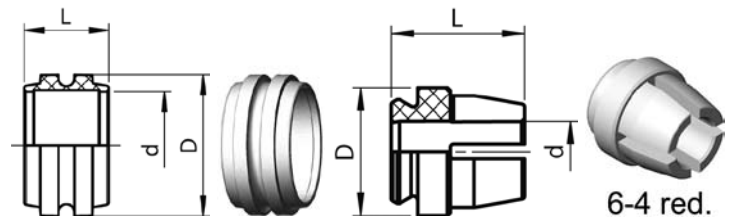

**SO 20001**

Type -d	Mat.-Nr.	bar	L	D	kg/100
SO 20001-6-4 RED	126.0014.110	10	9.0	8.6	0.034
SO 20001-6	126.0010.060	10	6.4	8.6	0.019
SO 20001-8	126.0010.080	10	6.4	10.7	0.025
SO 20001-10	126.0010.100	10	6.9	12.7	0.032
SO 20001-12	126.0010.120	10	7.5	14.8	0.043
SO 20001-16	126.0010.160	10	9.4	19.8	0.104

2

**Abschlusszapfen**  
**Bouchon d'arrêt**  
**Plug**

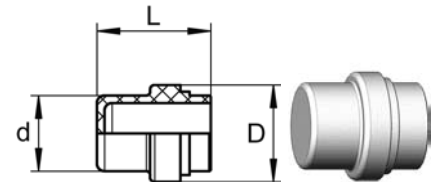

**SO 20002**

Type -d	Mat.-Nr.	bar	L	D	kg/100
SO 20002-6	126.0020.060	10	12.0	8.8	0.057
SO 20002-8	126.0020.080	10	12.5	10.8	0.080
SO 20002-10	126.0020.100	10	15.0	12.8	0.122
SO 20002-12	126.0020.120	10	17.0	14.8	0.165
SO 20002-16	126.0020.160	10	22.0	20.0	0.416

**Anwendungsbeispiele:**

**Exemples d'utilisation:**

**Sample combinations:**

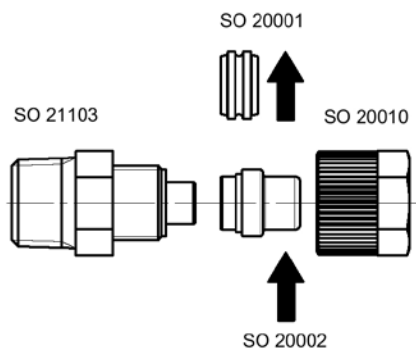

d=Rohrassen-ø  
 L= Mass in montiertem Zustand

d=ø extérieur du tube  
 L=après montage

d=tube outside diameter  
 L=installed length

**Sechskantmutter**  
**Ecrou à six pans**  
**Hexagon nut**

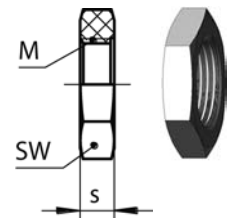

**SO 20006**

Type -M	Mat.-Nr.	SW	s	kg/100
SO 20006-M10X1	126.0063.150	14	4.50	0.085
SO 20006-M12X1	126.0063.190	17	4.50	0.124
SO 20006-M14X1	126.0063.220	19	4.50	0.143
SO 20006-M16X1	126.0063.260	22	5.00	0.214
SO 20006-M22X1,5	126.0063.375	30	5.00	0.380

Sechskantmutter für SO 21521 und Ventile

Ecrou à six pans pour SO 21521 et robinets

Hexagon nut for SO 21521 and valves

**Rändelmutter**  
**Ecrou moleté**  
**Knurled nut**

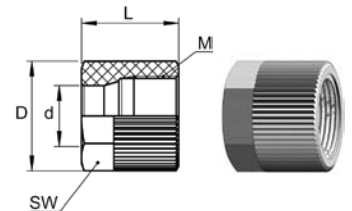

**SO 20020**

Type -d	Mat.-Nr.	bar	M	SW	L	D	kg/100
SO 20020-6	126.0100.060	10	10 x 1	12	14.5	14.0	0.215
SO 20020-8	126.0100.080	10	12 x 1	14	16.0	16.0	0.276
SO 20020-10	126.0100.100	10	14 x 1	17	17.5	19.0	0.479
SO 20020-12	126.0100.120	10	16 x 1	19	19.5	22.0	0.636
SO 20020-16	126.0100.160	10	22 x 1.5	24	25.0	27.0	1.166

d= Rohraussen-ø  
 L= Mass in montiertem Zustand  
 s=Wandstärke

d=ø extérieur du tube  
 L=après montage  
 s=épaisseur du paroi

d=tube outside diameter  
 L=installed length  
 s=wall thickness

# Übergangsmuffe Adaptateur femelle Female adaptor

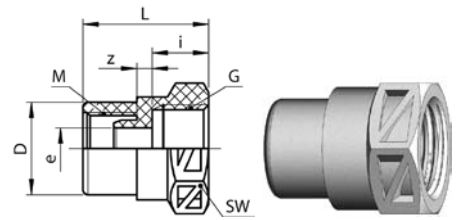

## SO 20030

Type -D-G	Mat.-Nr.	bar	M	L	SW	D	i	z	e	kg/100
G= Rohrgewinde (zylindrisch)	G= Filetage-gaz BSP (cylindrique)	G=BSP thread (straight)								
SO 20030-6-1/8	126.0301.100	10	10 x 1	20.5	14	13.0	9.0	3.0	4.0	3.010
SO 20030-6-1/4	126.0301.110	10	10 x 1	21.5	17	13.0	10.0	3.0	4.0	4.210
SO 20030-8-1/4	126.0301.170	10	12 x 1	23.0	17	15.0	10.0	3.0	6.0	4.680
SO 20030-10-1/4	126.0301.270	10	14 x 1	23.5	17	18.0	10.0	3.0	8.0	5.510
SO 20030-10-3/8	126.0301.280	10	14 x 1	24.5	22	18.0	11.0	3.0	8.0	7.730
SO 20030-12-3/8	126.0301.390	10	16 x 1	25.5	22	21.0	11.0	3.0	10.0	8.920
SO 20030-12-1/2	126.0301.400	10	16 x 1	29.0	27	21.0	14.0	3.5	10.0	14.180
SO 20030-16-3/8	126.0301.564	10	22 x 1,5	34.0	22	26.0	11.0	6.0	13.0	14.150
SO 20030-16-1/2	126.0301.566	10	22 x 1,5	37.5	27	26.0	14.0	6.5	13.0	18.850
SO 20030-16-3/4	126.0301.568	10	22 x 1,5	39.0	32	26.0	15.0	7.0	13.0	21.540

2

### Anwendungsbeispiele:

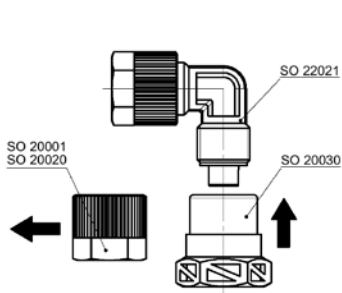

Die Übergangsmuffe SO 20030 kann an jedes SERTO-Formteil mit dem passenden zylindrischen Gewinde M (d) aufgeschraubt werden.

**Dichtungsprinzip:**  
Bei der Montage drückt sich die Dichtkante des Übergangsstückes in das SERTO-Formteil ein, dadurch entsteht eine einwandfreie Dichtung.

### Exemples d'utilisation:

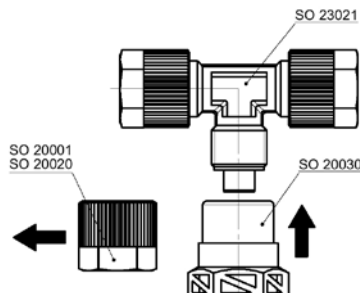

L'adaptateur femelle SO 20030 peut être monté sur toutes les pièces de forme SERTO avec le filetage cylindrique M (d) correspondant.

**Principe d'étanchéité:**  
Lors du serrage, le bourrelet s'enfonce dans la pièce de forme SERTO et donne un joint parfait.

### Sample combinations:

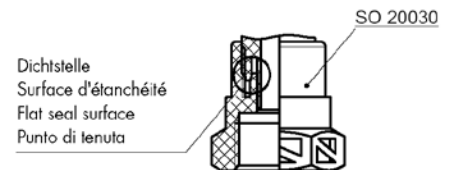

The female adaptor SO 20030 can be screwed onto every SERTO union body with the appropriate straight thread M (d).

**Sealing principle:**  
On being installed, the lip of the adaptor presses into the SERTO union body, forming a sound seal.

d=Rohrassen-ø  
e= kleinste Bohrung  
L= Mass in montiertem Zustand

d=ø extérieur du tube  
e= ø-min. de passage  
L=après montage

d=tube outside diameter  
e=minimum bore  
L=installed length

## Schlauchtülle

## Douille cannelée pour tuyau

## Hose nozzle

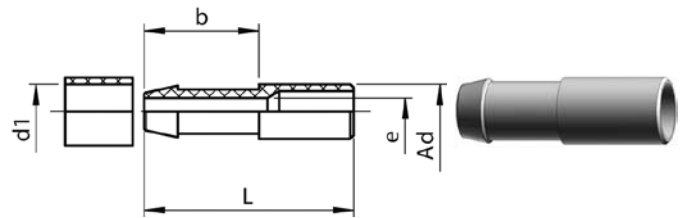

### SO 20503

Type -Ad -d1	Mat.-Nr.	bar	L	b	e	kg/100
SO 20503-A6-4	126.0500.045	10	24.0	11.0	3.0	0.052
SO 20503-A6-6	126.0500.060	10	30.0	17.0	4.0	0.098
SO 20503-A8-6	126.0500.063	10	31.0	17.0	4.0	0.123
SO 20503-A8-8	126.0500.080	10	31.0	17.0	6.0	0.140
SO 20503-A10-8	126.0500.083	10	32.0	17.0	6.0	0.169
SO 20503-A12-10	126.0500.103	10	38.0	19.0	7.0	0.291
SO 20503-A12-12	126.0500.120	10	38.0	19.0	10.0	0.265

Mit dieser Schlauchtülle können Gummischläuche und Rohre aus Teflon, Weich-PVC, Polyamid usw. direkt an SERTO-Verschraubungen angeschlossen werden.

Avec cette douille cannelée, les tuyaux en caoutchouc et les tubes en téflon, en PVC souple, en polyamide et autres peuvent être fixés directement aux raccords SERTO.

With this hose nozzle, rubber hoses and plastic hoses of teflon, soft PVC, polyamide can be connected directly to the SERTO unions.

Für die Schlauchsicherung verwenden Sie bitte unsere Schlauchklemme SO 40512 (Stahl promatverzinkt).

Afin d'assurer la bonne tenue des tuyaux, utiliser nos colliers de serrage SO 40512 (Acier zingué passivé).

Please use our hose clip SO 40512 (zinc promatised) for securing the hose.

## Gerade Verschraubung

## Union double

## Straight union

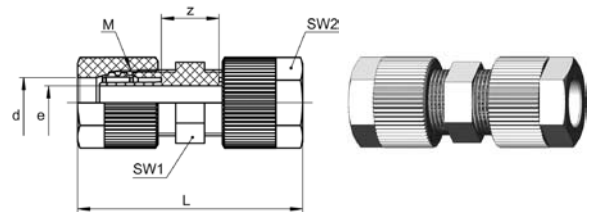

### SO 21021

Type -d	Mat.-Nr.	bar	M	SW1	SW2	L	z	e	kg/100
SO 21021-4	128.1000.040	10	10 x 1	12	12	39.0	16.5	2.8	0.718
SO 21021-6	128.1000.060	10	10 x 1	10	12	39.0	16.5	2.8	0.730
SO 21021-8	128.1000.080	10	12 x 1	12	14	42.0	17.5	4.8	0.976
SO 21021-10	128.1000.100	10	14 x 1	14	17	45.5	17.5	6.6	1.550
▼ SO 21021-10/7	128.1000.102	10	14 x 1	14	17	45.5	17.5	5.6	1.574
SO 21021-12	128.1000.120	10	16 x 1	17	19	49.0	16.0	8.0	2.105
▼ SO 21021-12/9	128.1000.122	10	16 x 1	17	19	49.0	16.0	7.0	2.126
▼ SO 21021-16/13	128.1000.160	10	22 x 1.5	22	24	69.5	24.0	11.0	4.445

Reduktionen siehe SO 21821

Réductions voir SO 21821

Reductions please see SO 21821

d=Rohraussen-ø  
d1=Rohrinnendurchmesser  
Ad=Aussen-ø der Andrehung  
e= kleinste Bohrung  
▼=für Rohre mit Wandung 1,5 mm

d= ø extérieur du tube  
d1= ø diam. intérieur du tube  
Ad=ø extérieur de la portée cylindrique  
e= ø-min. de passage  
▼=pour tubes avec paroi de 1,5 mm d'épaisseur

d=tube outside diameter  
d1=tube inside diameter  
Ad=outside diameter of cyl. stub  
e=minimum bore  
▼=for tubes with wall thickness of 1,5 mm





## Gerade Einschraubverschraubung

mit Dichtkante

### Union mâle

avec arête d'étanchéité

### Male adapter union

with edge seal

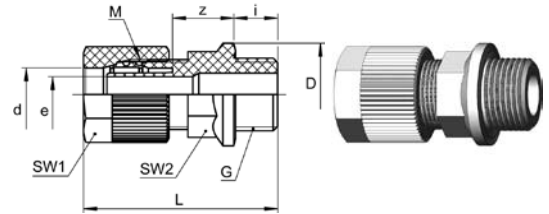

## SO 21124

Type -d-G	Mat.-Nr.	bar	M	SW1	SW2	L	D1	i	z	e	kg/100
G= Rohrgewinde (zylindrisch)	G= Filetage-gaz BSP (cylindrique)		G=BSP thread (straight)								
SO 21124-4-1/8	128.1161.060	10	10x1	12	10	34.5	16.0	8.0	15.5	2.8	0.571
SO 21124-4-1/4	128.1161.065	10	10x1	12	13	36.5	19.5	10.0	15.5	2.8	0.740
SO 21124-4-3/8	128.1161.068	10	10x1	12	17	37.5	23.5	10.0	16.5	2.8	1.055
SO 21124-4-1/2	128.1161.070	10	10x1	12	19	42.5	30.0	12.0	19.5	2.8	1.535
SO 21124-6-1/8	128.1161.100	10	10x1	12	10	34.5	16.0	8.0	15.5	2.8	0.577
SO 21124-6-1/4	128.1161.110	10	10x1	12	13	36.5	19.5	10.0	15.5	2.8	0.746
SO 21124-6-3/8	128.1161.120	10	10x1	12	17	37.5	23.5	10.0	16.5	2.8	1.061
SO 21124-6-1/2	128.1161.125	10	10x1	12	19	42.5	30.0	12.0	19.5	2.8	1.541
SO 21124-8-1/8	128.1161.160	10	12x1	14	10	35.5	16.0	8.0	15.5	4.8	0.690
SO 21124-8-1/4	128.1161.170	10	12x1	14	13	37.5	19.5	10.0	15.5	4.8	0.846
SO 21124-8-3/8	128.1161.180	10	12x1	14	17	38.5	23.5	10.0	16.5	4.8	1.170
SO 21124-8-1/2	128.1161.185	10	12x1	14	19	43.5	30.0	12.0	19.5	4.8	1.654
SO 21124-10-1/4	128.1161.270	10	14x1	17	13	39.0	19.5	10.0	15.0	6.6	1.097
SO 21124-10-3/8	128.1161.280	10	14x1	17	17	40.0	23.5	10.0	16.0	6.6	1.398
SO 21124-10-1/2	128.1161.285	10	14x1	17	19	45.5	30.0	12.0	19.0	6.6	1.908
SO 21124-12-1/4	128.1161.380	10	16x1	19	13	41.5	19.5	10.0	14.0	8.0	1.317
SO 21124-12-3/8	128.1161.390	10	16x1	19	17	41.5	23.5	10.0	15.0	8.0	1.632
SO 21124-12-1/2	128.1161.400	10	16x1	19	19	46.5	30.0	12.0	18.0	8.0	2.137

Reduktionen siehe SO 21821

Réductions voir SO 21821

Reductions please see SO 21821

d=Rohraussen-ø  
L= Mass in montiertem Zustand  
e= kleinste Bohrung

d= ø extérieur du tube  
L=après montage  
e= ø-min. de passage

d=tube outside diameter  
L=installed length  
e=minimum bore

## Gerade Einschraubverschraubung

Dichtung mit O-Ring (FPM)

### Union mâle

avec joint torique (FPM)

### Male adapter union

with O-Ring seal (FPM)

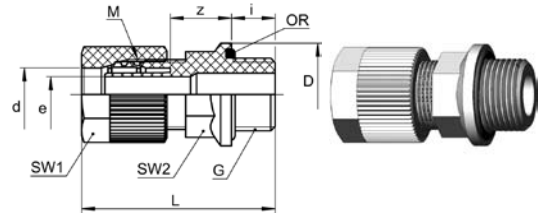

## SO 21124 OR

Type -d-G	Mat.-Nr.	bar	M	SW1	SW2	L	D	i	z	e	kg/100
G= Rohrgewinde (zylindrisch)	G= Filetage-gaz BSP (cylindrique)		G=BSP thread (straight)								
SO 21124-4-1/8 OR	128.1171.060	10	10x1	12	10	34.5	16.0	8.0	15.5	2.8	0.576
SO 21124-4-1/4 OR	128.1171.065	10	10x1	12	13	36.5	19.5	10.0	15.5	2.8	0.739
SO 21124-4-3/8 OR	128.1171.068	10	10x1	12	17	37.5	23.5	10.0	16.5	2.8	1.045
SO 21124-4-1/2 OR	128.1171.070	10	10x1	12	19	42.5	30.0	12.0	19.5	2.8	1.516
SO 21124-6-1/8 OR	128.1171.100	10	10x1	12	10	34.5	16.0	8.0	15.5	2.8	0.583
SO 21124-6-1/4 OR	128.1171.110	10	10x1	12	13	36.5	19.5	10.0	15.5	2.8	0.746
SO 21124-6-3/8 OR	128.1171.120	10	10x1	12	17	37.5	23.5	10.0	16.5	2.8	1.051
SO 21124-6-1/2 OR	128.1171.125	10	10x1	12	19	42.5	30.0	12.0	19.5	2.8	1.522
SO 21124-8-1/8 OR	128.1171.160	10	12x1	14	10	35.5	16.0	8.0	15.5	4.8	0.661
SO 21124-8-1/4 OR	128.1171.170	10	12x1	14	13	37.5	19.5	10.0	15.5	4.8	0.661
SO 21124-8-3/8 OR	128.1171.180	10	12x1	14	17	38.5	23.5	10.0	16.5	4.8	1.126
SO 21124-8-1/2 OR	128.1171.185	10	12x1	14	19	43.5	30.0	12.0	19.5	4.8	1.558
SO 21124-10-1/4 OR	128.1171.270	10	14x1	17	13	39.0	19.5	10.0	15.0	6.6	1.072
SO 21124-10-3/8 OR	128.1171.280	10	14x1	17	17	40.0	23.5	10.0	16.0	6.6	1.364
SO 21124-10-1/2 OR	128.1171.285	10	14x1	17	19	45.5	30.0	12.0	19.0	6.6	1.812
SO 21124-12-1/4 OR	128.1171.380	10	16x1	19	13	41.5	19.5	10.0	14.0	8.0	1.289
SO 21124-12-3/8 OR	128.1171.390	10	16x1	19	17	41.5	23.5	10.0	15.0	8.0	1.594
SO 21124-12-1/2 OR	128.1171.400	10	16x1	19	19	46.5	30.0	12.0	18.0	8.0	2.039
▼ SO 21124-12/9-1/4 OR	128.1171.410	10	16x1	19	13	14.0	19.5	10.0	14.0	7.0	1.334
▼ SO 21124-12/9-3/8 OR	128.1171.412	10	16x1	19	17	15.0	23.5	10.0	15.0	7.0	1.599
▼ SO 21124-12/9-1/2 OR	128.1171.414	10	16x1	19	19	18.0	30.0	12.0	18.0	7.0	1.989

Reduktionen siehe SO 21821

Réductions voir SO 21821

Reductions please see SO 21821

d=Rohrussen-ø  
 L= Mass in montiertem Zustand  
 e= kleinste Bohrung  
 ▼=für Rohre mit Wandung 1,5 mm

d= ø extérieur du tube  
 L=après montage  
 e= ø-min. de passage  
 ▼=pour tubes avec paroi de 1,5 mm d'épaisseur

d=tube outside diameter  
 L=installed length  
 e=minimum bore  
 ▼=for tubes with wall thickness of 1,5 mm

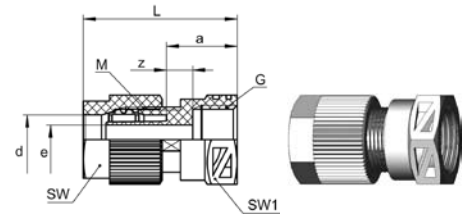
**Gerade Aufschraubverschraubung**
**Union simple femelle**
**Female adaptor union**

**SO 21221**

Type -d-G	Mat.-Nr.	bar	M	SW	SW1	L	a	z	e	kg/100
G= Rohrgewinde (zylindrisch)	G= Filetage-gaz BSP (cylindrique)	G=BSP thread (straight)								
SO 21221-4-1/8	128.1201.060	10	10 x 1	12	14	29.0	18.0	9.0	2.8	0.506
SO 21221-4-1/4	128.1201.065	10	10 x 1	12	17	30.0	19.0	9.0	2.8	0.618
SO 21221-4-3/8	128.1201.068	10	10 x 1	12	22	31.0	20.0	9.0	2.8	0.853
SO 21221-4-1/2	128.1201.070	10	10 x 1	12	27	34.5	23.0	9.5	2.8	1.392
SO 21221-6-1/8	128.1201.100	10	10 x 1	12	14	29.0	18.0	9.0	2.8	0.484
SO 21221-6-1/4	128.1201.110	10	10 x 1	12	17	30.0	19.0	9.0	2.8	0.594
SO 21221-6-3/8	128.1201.120	10	10 x 1	12	22	31.0	20.0	9.0	2.8	0.824
SO 21221-6-1/2	128.1201.125	10	10 x 1	12	27	34.5	23.0	9.5	2.8	1.354
SO 21221-8-1/4	128.1201.170	10	12 x 1	14	17	31.0	19.0	9.0	4.8	0.709
SO 21221-8-3/8	128.1201.180	10	12 x 1	14	22	33.0	20.0	9.0	4.8	0.919
SO 21221-8-1/2	128.1201.185	10	12 x 1	14	27	35.5	23.0	9.5	4.8	1.469
SO 21221-10-1/4	128.1201.270	10	14 x 1	17	17	33.5	18.0	8.5	6.6	0.943
SO 21221-10-3/8	128.1201.280	10	14 x 1	17	22	34.5	19.0	8.5	6.6	1.163
SO 21221-10-1/2	128.1201.285	10	14 x 1	17	27	37.0	23.0	9.0	6.6	1.683
▼ SO 21221-10/7-1/4	128.1201.320	10	14 x 1	17	17	33.0	18.0	8.5	5.0	0.963
▼ SO 21221-10/7-3/8	128.1201.330	10	14 x 1	17	22	34.0	19.0	8.5	5.0	1.183
▼ SO 21221-10/7-1/2	128.1201.335	10	14 x 1	17	27	37.0	23.0	9.0	5.0	1.713
SO 21221-12-3/8	128.1201.390	10	16 x 1	19	22	35.0	18.0	7.5	7.0	1.383
SO 21221-12-1/2	128.1201.400	10	16 x 1	19	27	37.5	22.0	8.0	8.0	1.933
▼ SO 21221-12/9-3/8	128.1201.412	10	16 x 1	19	22	35.0	18.0	7.5	7.0	1.423
▼ SO 21221-12/9-1/2	128.1201.414	10	16 x 1	19	27	37.5	22.0	8.0	8.0	1.963
▼ SO 21221-16/13-3/8	128.1201.564	10	22 x 1,5	24	22	43.5	22.0	11.0	11.0	1.374
▼ SO 21221-16/13-1/2	128.1201.566	10	22 x 1,5	24	27	47.0	25.0	11.5	11.0	2.884

Reduktionen siehe SO 21821

Réductions voir SO 21821

Reductions please see SO 21821

d=Rohrassens-ø  
 L= Mass in montiertem Zustand  
 e= kleinste Bohrung  
 ▼=für Rohre mit Wandung 1,5 mm

d= ø extérieur du tube  
 L=après montage  
 e= ø-min. de passage  
 ▼=pour tubes avec paroi de 1,5 mm d'épaisseur

d=tube outside diameter  
 L=installed length  
 e=minimum bore  
 ▼=for tubes with wall thickness of 1,5 mm

**Verbindungsrippel**

**Pièce folle**

**Tube stub**

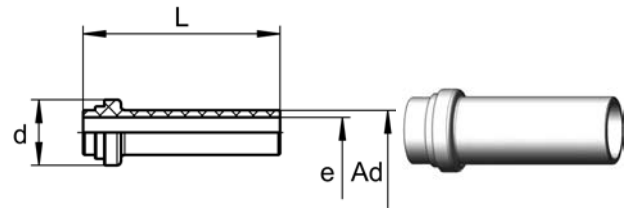

**SO 21300**

Type -d1 -d2	Mat.-Nr.	bar	L1	d2	e	kg/100
SO 21300-6-A6	126.1300.060	10	20.8	8.60	4.0	0.089
SO 21300-8-A8	126.1300.080	10	20.9	10.60	6.0	0.134
SO 21300-10-A10	126.1300.100	10	25.0	12.60	8.0	0.200
SO 21300-12-A12	126.1300.120	10	27.5	14.60	10.0	0.268
▼ SO 21300-12/9-A12	126.1300.122	10	27.5	14.60	9.0	0.366
▼ SO 21300-16/13-A16/13	126.1300.160	10	35.5	19.70	13.0	0.673

**Verbindungsrippel reduziert**

**Pièce folle réduite**

**Reduction port connector**

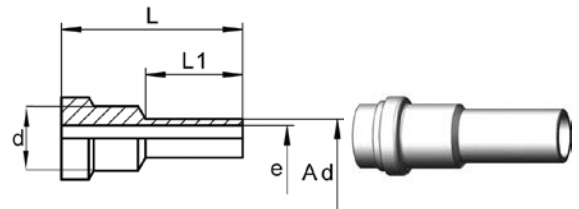

**SO 21300 RED**

Type -d -Ad	Mat.-Nr.	bar	L	L1	D	e	kg/100
SO 21300-6-A4 RED	126.1304.110	10	29.0	15.0	8.6	2.0	0.083
SO 21300-8-A6 RED	126.1304.140	10	30.0	15.0	10.6	4.0	0.125
SO 21300-10-A6 RED	126.1304.175	10	35.0	15.0	12.6	4.0	0.177
SO 21300-10-A8 RED	126.1304.190	10	35.0	15.0	12.6	6.0	0.194
SO 21300-12-A8 RED	126.1304.225	10	39.0	19.0	14.6	6.0	0.239
SO 21300-12-A10 RED	126.1304.240	10	39.0	19.0	14.6	8.0	0.260
▼ SO 21300-12/9-A10 RED	126.1304.272	10	39.0	19.0	14.6	8.0	0.312
▼ SO 21300-16/13-A12 RED	126.1304.480	10	50.0	25.0	19.7	10.0	0.556

**Anwendungsbeispiele:**

**Exemples d'utilisation:**

**Sample combinations:**

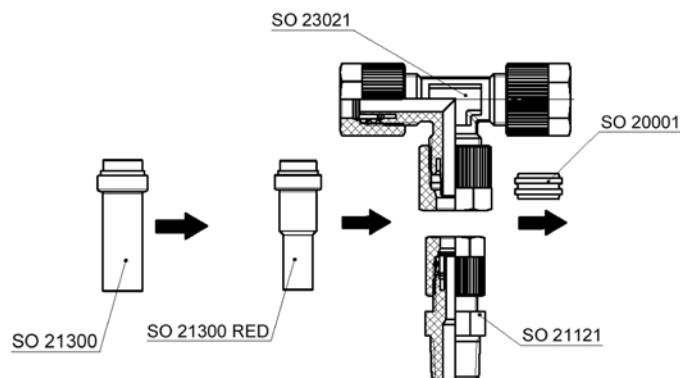

Ad=Aussen-ø der Aendrehung  
 d=Rohraussen-ø  
 L= Mass in montiertem Zustand  
 e= kleinste Bohrung  
 ▼=für Rohre mit Wandung 1,5 mm

Ad=ø extérieur de la portée cylindrique  
 d=ø extérieur du tube  
 L=après montage  
 e= ø-min. de passage  
 ▼=pour tubes avec paroi de 1,5 mm d'épaisseur

Ad= outside diameter of cyl. stub  
 d=tube outside diameter  
 L=installed length  
 e=minimum bore  
 ▼=for tubes with wall thickness of 1,5 mm

**Gerade Schottverschraubung**  
**Union double pour passage de cloison**  
**Panel mount union**

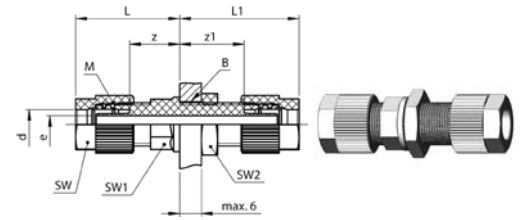

**SO 21521**

Type -d	Mat.-Nr.	bar	M	SW1	SW2	L	L1	B	z1	z	e	kg/100
SO 21521-4	128.1500.040	10	10 x 1	10	14	24.0	28.0	10.5	17.0	13.0	2.8	0.979
SO 21521-6	128.1500.060	10	10 x 1	14	14	24.0	28.0	10.5	17.0	13.0	2.8	0.991
SO 21521-8	128.1500.080	10	12 x 1	12	17	26.0	30.0	12.5	18.0	14.0	4.8	1.344
SO 21521-10	128.1500.100	10	14 x 1	14	19	28.5	31.5	14.5	17.5	14.0	6.6	2.007
▼ SO 21521-10/7	128.1500.102	10	14 x 1	19	19	28.5	27.5	14.5	17.5	14.0	5.6	2.054
SO 21521-12	128.1500.120	10	16 x 1	17	19	30.0	28.5	16.5	20.0	13.5	8.0	2.812
▼ SO 21521-12/9	128.1500.122	10	16 x 1	17	19	30.0	28.5	16.5	20.0	13.5	7.0	2.870
▼ SO 21521-16/13	128.1500.160	10	22 x 1.5	30	22	41.0	51.0	22.5	28.0	18.0	11.0	4.634

Sechskantmutter SO 20006  
 Reduktionen siehe SO 21821

Ecrou à six pans SO 20006  
 Réductions voir SO 21821

Hexagon nut SO 20006  
 Reductions please see SO 21821

2

d=Rohraussen-ø  
 e= kleinste Bohrung  
 L= Mass in montiertem Zustand

d=ø extérieur du tube  
 e= ø-min. de passage  
 L=après montage

d=tube outside diameter  
 e=minimum bore  
 L=installed length

**Einstellnippel**  
**Union orientable mâle**  
**Adjustable male adapter**

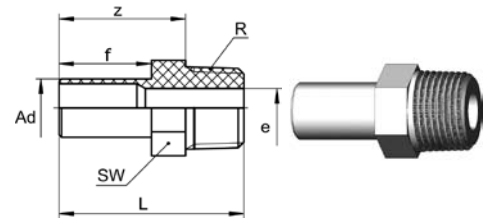

**SO 21600**

Type -Ad-R	Mat.-Nr.	bar	SW	L	f	z	e	kg/100
R= Rohrgewinde (kegelig)	R= Filetage-gaz BSP (conique)	R=BSP thread (tapered)						
SO 21600-A6-1/8	126.1601.100	10	10	26.0	13.0	18.0	4.0	0.173
SO 21600-A6-1/4	126.1601.110	10	14	31.5	13.0	19.5	4.0	0.420
SO 21600-A6-3/8	126.1601.120	10	17	32.0	13.0	20.0	4.0	0.650
SO 21600-A6-1/2	126.1601.125	10	22	37.0	13.0	21.0	4.0	1.190
SO 21600-A8-1/8	126.1601.160	10	10	27.0	14.0	19.0	6.0	0.198
SO 21600-A8-1/4	126.1601.170	10	14	32.5	14.0	20.5	6.0	0.444
SO 21600-A8-3/8	126.1601.180	10	17	33.0	14.0	21.0	6.0	0.672
SO 21600-A8-1/2	126.1601.185	10	22	38.0	14.0	22.0	6.0	1.200
SO 21600-A10-1/4	126.1601.270	10	14	33.5	15.0	21.5	8.0	0.451
SO 21600-A10-3/8	126.1601.280	10	17	34.0	15.0	22.0	8.0	0.692
SO 21600-A10-1/2	126.1601.285	10	22	39.0	15.0	23.0	8.0	1.200
SO 21600-A12-1/4	126.1601.380	10	14	37.5	19.0	25.5	10.0	0.506
SO 21600-A12-3/8	126.1601.390	10	17	38.0	19.0	26.0	10.0	0.725
SO 21600-A12-1/2	126.1601.400	10	22	43.0	19.0	27.0	10.0	1.251
SO 21600-A16-3/8	126.1601.564	10	17	44.0	25.0	32.0	13.0	0.957
SO 21600-A16-1/2	126.1601.566	10	22	49.0	25.0	33.0	13.0	1.299
SO 21600-A16-3/4	126.1601.568	10	27	50.5	25.0	34.0	13.0	2.119

**Anwendungsbeispiele:**

**Exemples d'utilisation:**

**Sample combinations:**

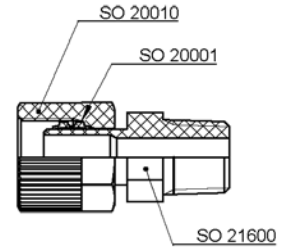
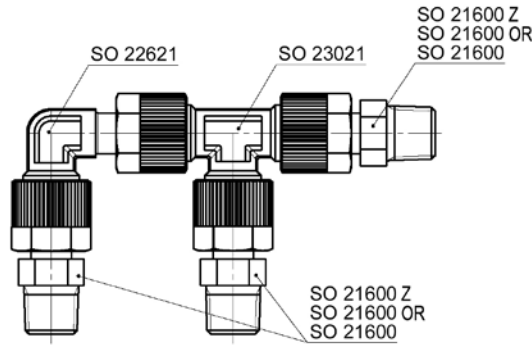
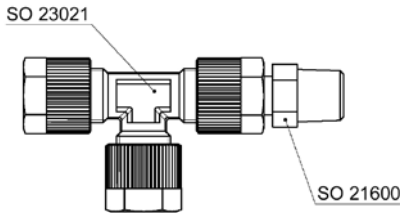

Reduktionen siehe SO 21821

Réductions voir SO 21821

Reductions please see SO 21821

Ad=Aussen-ø der Andrehung  
 e= kleinste Bohrung  
 L= Mass in montiertem Zustand

Ad=ø extérieur de la portée cylindrique  
 e= ø-min. de passage  
 L=après montage

Ad= outside diameter of cyl. Stub  
 e=minimum bore  
 L=installed length

# Einstellnippel

mit Dichtkante

# Union orientable mâle

avec arête d'étanchéité

# Adjustable male adaptor

with edge seal

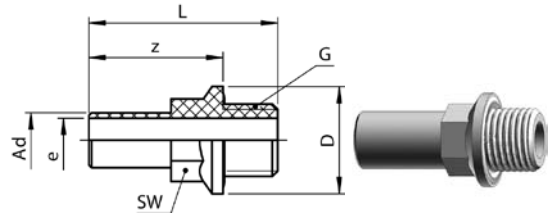

## SO 21624

2

Type -Ad -G	Mat.-Nr.	bar	SW	L	D	f	z	e	kg/100
G= Rohrgewinde (zylindrisch)	G= Filetage-gaz BSP (cylindrique)	G=BSP thread (straight)							
SO 21624-A6-1/8 Z	126.1661.100	10	10	30.5	16.0	13.0	22.5	5.1	0.288
SO 21624-A6-1/4 Z	126.1661.110	10	13	32.5	19.5	13.0	22.5	7.8	0.451
SO 21624-A6-3/8 Z	126.1661.120	10	17	33.5	23.5	13.0	23.5	9.8	0.766
SO 21624-A8-1/8 Z	126.1661.160	10	10	31.5	16.0	14.0	23.5	5.1	0.307
SO 21624-A8-1/4 Z	126.1661.170	10	13	33.5	19.5	14.0	23.5	7.8	0.466
SO 21624-A8-3/8 Z	126.1661.180	10	17	34.5	23.5	14.0	24.5	9.8	0.784
SO 21624-A8-1/2 Z	126.1661.185	10	13	34.5	19.5	8.0	24.5	8.0	0.469
SO 21624-A10-1/4 Z	126.1661.270	10	13	34.5	19.5	15.0	24.5	8.0	0.469
SO 21624-A10-3/8 Z	126.1661.280	10	17	35.5	23.5	15.0	25.5	9.8	0.779
SO 21624-A10-1/2 Z	126.1661.285	10	19	40.5	30.0	15.0	28.5	14.0	1.281
SO 21624-A12-1/4 Z	126.1661.380	10	13	38.5	19.5	19.0	28.5	11.2	0.529
SO 21624-A12-3/8 Z	126.1661.390	10	17	39.5	23.5	19.0	29.5	10.0	0.798
SO 21624-A12-1/2 Z	126.1661.400	10	19	44.5	30.0	19.0	32.5	14.0	1.279
SO 21624-A16-3/8 Z	126.1661.564	10	17	45.5	23.5	25.0	35.5	9.8	1.041
SO 21624-A16-1/2 Z	126.1661.566	10	19	50.5	30.0	25.0	38.5	13.0	1.510
SO 21624-A16-3/4 Z	126.1661.568	10	22	55.0	35.0	25.0	41.0	16.0	2.405

Anwendungsbeispiele:

Exemples d'utilisation:

Sample combinations:

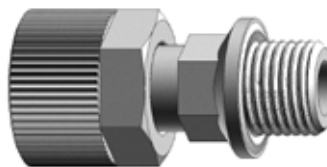
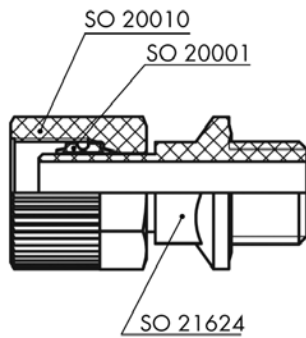

Ad=Aussen-ø der Andrehung  
e= kleinste Bohrung  
L= Mass in montiertem Zustand

Ad=ø extérieur de la portée cylindrique  
e= ø-min. de passage  
L=après montage

Ad= outside diameter of cyl. Stub  
e=minimum bore  
L=installed length

### Einstellnippel

Dichtung mit O-Ring (FPM)

### Union orientable mâle

avec joint torique (FPM)

### Adjustable male adaptor

with O-Ring seal (FPM)

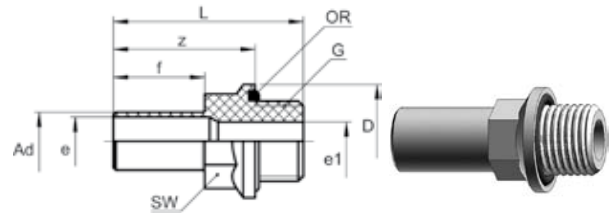

## SO 21624 OR

Type -Ad-G	Mat.-Nr.	bar	SW	L	D	z	e	e1	kg/100
G= Rohrgewinde (zylindrisch)	G= Filetage-gaz BSP (cylindrique)	G=BSP thread (straight)							
SO 21624-A6-1/8 OR	126.1681.100	10	10	30.5	16.0	22.5	4.0	5.1	0.268
SO 21624-A6-1/4 OR	126.1681.110	10	13	32.5	19.5	22.5	4.0	7.8	0.425
SO 21624-A6-3/8 OR	126.1681.120	10	17	33.5	23.5	23.5	4.0	9.8	0.730
SO 21624-A6-1/2 OR	126.1681.125	10	19	38.5	30.0	26.5	4.0	3.0	1.206
SO 21624-A8-1/8 OR	126.1681.160	10	10	31.5	16.0	23.5	6.0	5.1	0.288
SO 21624-A8-1/4 OR	126.1681.170	10	13	33.5	19.5	23.5	6.0	7.8	0.440
SO 21624-A8-3/8 OR	126.1681.180	10	17	34.5	23.5	24.5	6.0	9.8	0.745
SO 21624-A8-1/2 OR	126.1681.185	10	19	39.5	30.0	27.5	8.0	6.5	1.225
SO 21624-A10-1/4 OR	126.1681.270	10	13	34.5	19.5	24.5	8.0	8.0	0.443
SO 21624-A10-3/8 OR	126.1681.280	10	17	35.5	23.5	25.5	8.0	9.8	0.740
SO 21624-A10-1/2 OR	126.1681.285	10	19	40.5	30.0	28.5	8.0	14.0	1.185
SO 21624-A12-1/4 OR	126.1681.380	10	13	38.5	19.5	28.5	10.0	7.8	0.508
SO 21624-A12-3/8 OR	126.1681.390	10	17	39.5	23.5	29.5	10.0	10.0	0.762
SO 21624-A12-1/2 OR	126.1681.400	10	19	44.5	30.0	32.5	10.0	14.0	1.182
SO 21624-A16-3/8 OR	126.1681.564	10	17	45.5	23.5	35.5	13.0	9.8	0.996
SO 21624-A16-1/2 OR	126.1681.566	10	19	50.5	30.0	38.5	13.0	13.0	1.412
SO 21624-A16-3/4 OR	126.1681.568	10	22	54.0	35.0	40.0	13.0	16.0	2.286

#### Anwendungsbeispiele:

#### Exemples d'utilisation:

#### Sample combinations:

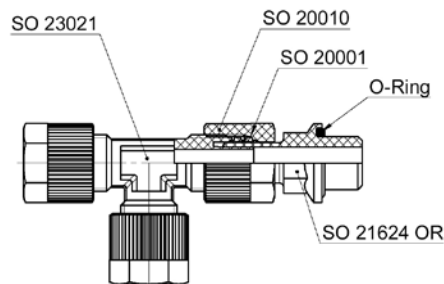

Ad=Aussen-ø der Andrehung  
e= kleinste Bohrung  
L= Mass in montiertem Zustand

Ad=ø extérieur de la portée cylindrique  
e= ø-min. de passage  
L=après montage

Ad= outside diameter of cyl. Stub  
e=minimum bore  
L=installed length

## Reduktionsverschraubungen

### Réduction

### Reduced union

## SO 21821

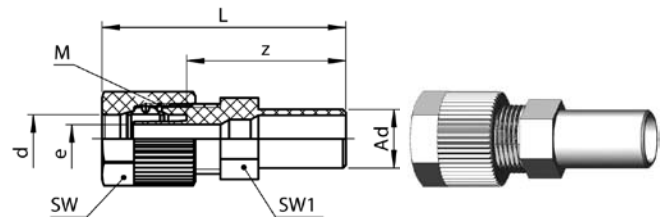

Type -Ad-d	Mat.-Nr.	bar	M	SW	SW1	L	f	z	e	kg/100
▼ SO 21821-A8-4	128.1800.132	10	10x1	12	10	35.5	14.0	26.0	2.8	0.428
▼ SO 21821-A8-6	128.1800.140	10	10x1	12	10	35.5	14.0	26.0	2.8	0.435
▼ SO 21821-A10-6	128.1800.175	10	10x1	12	10	38.0	15.0	27.5	2.8	0.446
▼ SO 21821-A10-8	128.1800.190	10	12x1	14	12	39.5	15.0	27.5	4.8	0.588
▼ SO 21821-A12-6	128.1800.215	10	10x1	12	10	42.0	19.0	32.0	2.8	0.509
▼ SO 21821-A12-8	128.1800.225	10	12x1	14	12	43.5	19.0	32.0	4.8	0.621
▼ SO 21821-A12-10	128.1800.240	10	14x1	17	14	45.0	19.0	31.5	6.6	0.934
▼ SO 21821-A12-10/7	128.1800.242	10	14x1	17	14	45.0	19.0	31.5	5.6	0.941
▼ SO 21821-A16-12	128.1800.480	10	16x1	19	17	54.0	25.0	37.5	8.0	1.441

2

#### Anwendungsbeispiele:

#### Exemples d'utilisation:

#### Sample combinations:

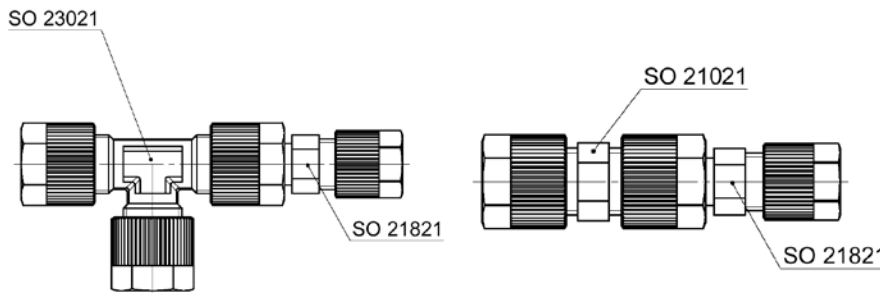

Mit dieser Reduktion können Verschraubungen reduziert werden.

Cette réduction permet de réduire les raccords.

Unions can be reduced with this reduction.

## Winkelverschraubung

### Coude

### Elbow union

## SO 22021

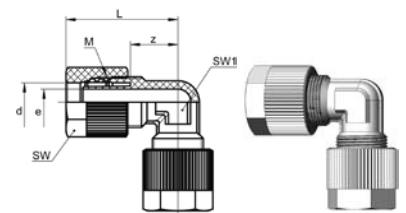

Type -d	Mat.-Nr.	bar	M	SW	SW1	L	z	e	kg/100
SO 22021-4	128.2000.040	10	10 x 1	12	8	25.0	14.0	2.8	0.770
SO 22021-6	128.2000.060	10	10 x 1	12	8	25.0	14.0	2.8	0.782
SO 22021-8	128.2000.080	10	12 x 1	14	10	26.5	14.5	4.8	1.040
SO 22021-10	128.2000.100	10	14 x 1	17	12	30.0	16.0	6.6	1.679
▼ SO 22021-10/7	128.2000.102	10	14 x 1	17	12	30.0	16.0	5.6	1.727
SO 22021-12	128.2000.120	10	16 x 1	19	13	32.5	16.0	8.0	2.188
▼ SO 22021-12/9	128.2000.122	10	16 x 1	19	13	32.5	16.0	7.0	2.242
▼ SO 22021-16/13	128.2000.160	10	22 x 1,5	24	19	45.5	23.0	11.0	4.989

Reduktionen siehe SO 21821

Réductions voir SO 21821

Reductions please see SO 21821

d=Rohrassen-ø  
Ad=Aussen-ø der Andrehung  
e= kleinste Bohrung  
L= Mass in montiertem Zustand  
▼=für Rohre mit Wandung 1,5 mm

d=ø extérieur du tube  
Ad=ø extérieur de la portée cylindrique  
e= ø-min. de passage  
L=après montage  
▼=pour tubes avec paroi de 1,5 mm d'épaisseur

d=tube outside diameter  
Ad= outside diameter of cyl. Stub  
e=minimum bore  
L=installed length  
▼=for tubes with wall thickness of 1,5 mm

## Winkelverschraubung

mit Übergangsmuffe

### Coude

avec adaptateur femelle

### Elbow union

with female adaptor

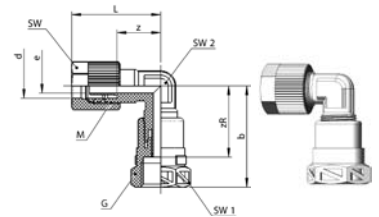
**SO 22221**

Type -d-G	Mat.-Nr.	bar	M	SW	SW1	SW2	L	b	zR	z	e	kg/100
G= Rohrgewinde (zylindrisch)	G= Filetage-gaz BSP (cylindrique)			G=BSP thread (straight)								
SO 22221-4-1/8	128.2201.060	10	10x1	12	14	8	25.0	31.0	22.0	14.0	2.8	0.550
SO 22221-4-1/4	128.2201.065	10	10x1	12	17	8	25.0	32.0	22.0	14.0	2.8	0.670
SO 22221-6-1/8	128.2201.100	10	10x1	12	14	8	25.0	31.0	22.0	14.0	2.8	0.535
SO 22221-6-1/4	128.2201.110	10	10x1	12	17	8	25.0	32.0	22.0	14.0	2.8	0.655
SO 22221-8-1/4	128.2201.170	10	12x1	14	17	10	26.5	33.5	23.5	14.5	4.8	0.769
SO 22221-10-1/4	128.2201.270	10	14x1	17	17	12	30.0	36.5	26.5	16.0	6.6	1.062
SO 22221-10-3/8	128.2201.280	10	14x1	17	22	12	30.0	37.5	26.5	16.0	6.6	1.284
▼ SO 22221-10/7-1/4	128.2201.320	10	14x1	17	17	12	30.0	36.5	26.5	16.0	5.6	1.062
▼ SO 22221-10/7-3/8	128.2201.330	10	14x1	17	22	12	30.0	37.5	26.5	16.0	5.6	1.284
SO 22221-12-3/8	128.2201.390	10	16x1	19	22	13	32.5	39.0	28.0	16.0	8.0	1.560
SO 22221-12-1/2	128.2201.400	10	16x1	19	27	13	32.5	42.5	28.5	16.0	8.0	2.086
▼ SO 22221-12/9-3/8	128.2201.412	10	16x1	19	22	13	32.5	39.0	28.0	16.0	7.0	1.560
▼ SO 22221-12/9-1/2	128.2201.414	10	16x1	19	27	13	32.5	42.5	28.5	16.0	7.0	2.086
▼ SO 22221-16/13-3/8	128.2201.564	10	22x1.5	24	22	19	45.5	52.5	41.5	23.0	11.0	2.685
▼ SO 22221-16/13-1/2	128.2201.566	10	22x1.5	24	27	19	45.5	56.0	42.0	23.0	11.0	3.155
▼ SO 22221-16/13-3/4	128.2201.568	10	22x1.5	24	32	19	45.5	57.5	42.5	23.0	11.0	3.424

Die Übergangsmuffe SO 20030 ist lose aufgeschraubt. Beim Anziehen dichtet die angedrehte Dichtkante ab.

L'adaptateur femelle SO 20030 est monté librement. Lors du serrage, l'arête d'étanchéité forme un joint parfait.

The female adaptor SO 20030 is screwed on loosely. The integrally turned sealing lip produces a seal on being tightened.

Kombinationsbeispiele siehe SO 20030

Exemples d'utilisation voir SO 20030

Sample combinations see SO 20030

Weitere Verschraubungen mit Innengewinde siehe SO 21221, SO 22521 und SO 23221.

Autres raccords avec adaptateur femelle, voir SO 21221, SO 22521 et SO 23221.

Alternative unions with female adaptor see SO 21221, SO 22521 and SO 23221.

d=Rohrassen-ø  
e= kleinste Bohrung  
L= Mass in montiertem Zustand  
▼=für Rohre mit Wandung 1,5 mm

d=ø extérieur du tube  
e= ø-min. de passage  
L=après montage  
▼=pour tubes avec paroi de 1,5 mm d'épaisseur

d=tube outside diameter  
e=minimum bore  
L=installed length  
▼=for tubes with wall thickness of 1,5 mm

## Winkel-Einschraubverschraubung

### Coude mâle

### Male adaptor elbow union

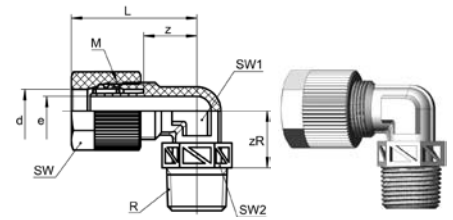

## SO 22421

Type -d-R	Mat.-Nr.	bar	M	SW	SW1	SW2	L	zR	z	e	kg/100
R= Rohrgewinde (kegelig)	R= Filetage-gaz BSP (conique)	R=BSP thread (tapered)									
SO 22421-4-1/8	128.2401.060	10	10x1	12	8	10	25.0	11.0	14.0	2.8	0.564
SO 22421-4-1/4	128.2401.065	10	10x1	12	8	14	25.0	12.5	14.0	2.8	0.785
SO 22421-6-1/8	128.2401.100	10	10x1	12	8	10	25.0	11.0	14.0	2.8	0.570
SO 22421-6-1/4	128.2401.110	10	10x1	12	8	14	25.0	12.5	14.0	2.8	0.791
SO 22421-8-1/8	128.2401.160	10	12x1	14	10	10	26.5	12.0	14.5	4.8	0.720
SO 22421-8-1/4	128.2401.170	10	12x1	14	10	14	26.0	13.5	14.5	4.8	0.941
SO 22421-10-1/4	128.2401.270	10	14x1	17	12	14	30.0	14.5	16.0	6.6	1.291
SO 22421-10-3/8	128.2401.280	10	14x1	17	12	17	30.0	15.0	15.5	6.6	1.511
▼ SO 22421-10/7-1/4	128.2401.320	10	14x1	17	12	14	30.0	14.5	16.0	5.6	1.314
▼ SO 22421-10/7-3/8	128.2401.330	10	14x1	17	12	17	30.0	15.0	16.0	5.6	1.531
SO 22421-12-1/4	128.2401.380	10	16x1	19	13	14	32.5	15.5	16.0	8.0	1.576
SO 22421-12-3/8	128.2401.390	10	16x1	19	13	17	32.5	16.0	16.0	8.0	1.774
SO 22421-12-1/2	128.2401.400	10	16x1	19	13	22	32.5	19.5	16.0	8.0	2.349
▼ SO 22421-12/9-1/4	128.2401.410	10	16x1	19	13	14	32.5	15.5	16.0	7.0	1.604
▼ SO 22421-12/9-3/8	128.2401.412	10	16x1	19	13	17	32.5	16.0	16.0	7.0	1.801
▼ SO 22421-12/9-1/2	128.2401.414	10	16x1	19	13	22	32.5	19.5	16.0	7.0	2.401
▼ SO 22421-16/13-3/8	128.2401.564	10	22x1,5	24	19	17	45.5	19.0	23.0	11.0	2.940
▼ SO 22421-16/13-1/2	128.2401.566	10	22x1,5	24	19	22	45.5	22.5	23.0	11.0	3.339

## Einschraubwinkel NPT

### Coude mâle NPT

### Male adaptor elbow union NPT

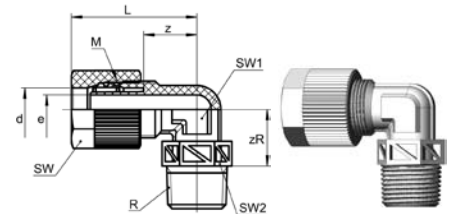

## SO 22421 NPT

Type -d-R	Mat.-Nr.	bar	M	SW	SW1	SW2	L	zR	z	e	kg/100
R= NPT Gewinde	R= Filetage NPT	R= NPT thread									
SO 22421-4-1/8 NPT	128.2402.060	10	10x1	12	8	11	25.0	11.0	14.0	2.8	0.614
SO 22421-4-1/4 NPT	128.2402.065	10	10x1	12	8	14	25.0	12.5	14.0	2.8	0.834
SO 22421-6-1/8 NPT	128.2402.100	10	10x1	12	8	11	25.0	11.0	14.0	2.8	0.620
SO 22421-6-1/4 NPT	128.2402.110	10	10x1	12	8	14	25.0	12.5	14.0	2.8	0.840
SO 22421-8-1/8 NPT	128.2402.160	10	12x1	14	10	11	26.5	12.0	14.5	4.8	0.771
SO 22421-8-1/4 NPT	128.2402.170	10	12x1	14	10	14	26.5	13.5	14.5	4.8	0.990
SO 22421-10-1/4 NPT	128.2402.270	10	14x1	17	12	14	30.0	14.5	16.0	6.6	1.335
SO 22421-10-3/8 NPT	128.2402.280	10	14x1	17	12	17	30.0	15.0	16.0	6.6	1.572
▼ SO 22421-10/7-1/4 NPT	128.2402.320	10	14x1	17	12	14	30.0	14.5	16.0	5.6	1.358
▼ SO 22421-10/7-3/8 NPT	128.2402.330	10	14x1	17	12	17	30.0	15.0	16.0	5.6	1.596

Zum Abdichten der Einschraubgewinde empfehlen wir Teflonband.

Pour assurer l'étanchéité des filetages mâles, nous recommandons téflon en bande.

For sealing the male threads we recommend teflon tape.

Reduktionen siehe SO 21821

Réductions voir SO 21821

Reductions please see SO 21821

d=Rohrassen-ø  
e= kleinste Bohrung  
L= Mass in montiertem Zustand  
▼=für Rohre mit Wandung 1,5 mm

d=ø extérieur du tube  
e= ø-min. de passage  
L=après montage  
▼=pour tubes avec paroi de 1,5 mm d'épaisseur

d=tube outside diameter  
L=installed length  
e=minimum bore  
▼=for tubes with wall thickness of 1,5 mm

**Einstellwinkel**  
**Coude orientable**  
**Adjustable elbow union**

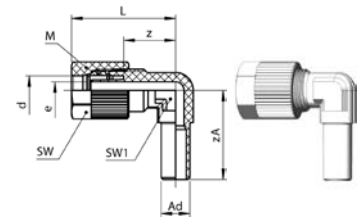

**SO 22621**

Type -d -Ad	Mat.-Nr.	bar	M	SW	SW1	L	f	zA	z	e	kg/100
SO 22621-4-A6	128.2600.045	10	10x1	12	8	25.0	14.0	24.0	14.0	2.8	0.516
SO 22621-6-A6	128.2600.060	10	10x1	12	8	25.0	14.0	24.0	14.0	2.8	0.507
SO 22621-8-A8	128.2600.080	10	12x1	14	10	26.5	16.0	25.0	14.5	4.8	0.695
SO 22621-10-A10	128.2600.100	10	14x1	17	12	30.0	18.0	29.0	16.0	6.6	1.082
SO 22621-12-A12	128.2600.120	10	16x1	19	13	32.5	21.0	32.0	16.0	8.0	1.399

**Anwendungsbeispiele:**

**Exemples d'utilisation:**

**Sample combinations:**

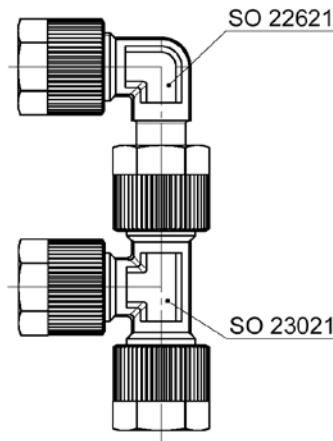

**Winkelschottverschraubung**  
**Coude pour passage cloison**  
**Panel mount elbow union**

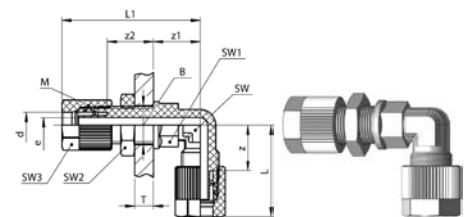

**SO 22721**

Type -d	Mat.-Nr.	bar	M	SW1	SW2	SW3	L	L1	z	z1	T	e	kg/100
SO 22721-4	128.2700.040	10	10x1	10	14	12	25.0	36.0	14.0	13.0	6.0	2.8	1.142
SO 22721-6	128.2700.060	10	10x1	10	14	12	25.0	40.0	14.0	13.0	6.0	2.8	1.122
SO 22721-8	128.2700.080	10	12x1	12	17	14	26.5	43.0	14.5	15.0	6.0	4.8	1.506
SO 22721-10	128.2700.100	10	14x1	14	19	17	30.0	46.0	16.0	16.5	6.0	6.6	2.136
SO 22721-10/7	128.2700.102	10	14x1	14	19	17	30.0	46.0	16.0	16.5	6.0	5.6	3.062
SO 22721-12	128.2700.120	10	16x1	17	22	19	32.5	48.5	16.0	17.5	5.0	8.0	2.869
SO 22721-12/9	128.2700.122	10	16x1	17	22	19	32.5	48.5	16.0	17.5	5.0	7.0	2.949
SO 22721-16/13	128.2700.160	10	22x1.5	22	30	24	45.5	54.0	23.0	19.5	3.0	11.0	5.848

Sechskantmutter SO 20006

Ecrou à six pans SO 20006

Hexagon nut SO 20006

d=Rohrassen-ø  
 Ad=Aussen-ø der Andrehung  
 e= kleinste Bohrung  
 L= Mass in montiertem Zustand  
 T=maximale Durchführungs-länge

d=ø extérieur du tube  
 Ad=ø extérieur de la portée cylindrique  
 e= ø-min. de passage  
 L=après montage  
 T=cloison max.

d=tube outside diameter  
 Ad= outside diameter of cyl. Stub  
 e=minimum bore  
 L=installed length  
 T=max. panel thickness

**T-Verschraubung**

**Té**

**Tee union**

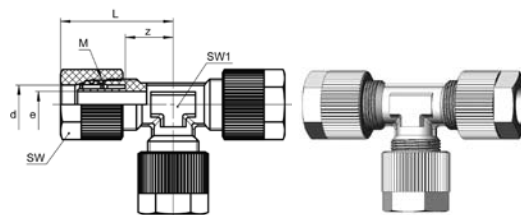

**SO 23021**

Type -d	Mat.-Nr.	bar	M	SW	SW1	L	z	e	kg/100
SO 23021-4	128.3000.040	10	10 x 1	12	8	25.0	14.0	2.8	1.132
SO 23021-6	128.3000.060	10	10 x 1	12	8	25.0	14.0	2.8	1.149
SO 23021-8	128.3000.080	10	12 x 1	14	10	26.5	14.5	4.8	1.520
SO 23021-10	128.3000.100	10	14 x 1	17	12	30.0	16.0	6.6	2.449
▼ SO 23021-10/7	128.3000.102	10	14 x 1	17	12	30.0	16.0	5.6	2.512
SO 23021-12	128.3000.120	10	16 x 1	19	13	32.5	16.0	8.0	3.202
▼ SO 23021-12/9	128.3000.122	10	16 x 1	19	13	32.5	16.0	7.0	3.275
▼ SO 23021-16/13	128.3000.160	10	22 x 1,5	24	19	45.5	23.0	11.0	7.211

Reduktionen siehe SO 21821

Réductions voir SO 21821

Reductions please see SO 21821

2

d=Rohrassen-ø  
 e= kleinste Bohrung  
 L= Mass in montiertem Zustand  
 ▼=für Rohre mit Wandung 1,5 mm

d=ø extérieur du tube  
 e= ø-min. de passage  
 L=après montage  
 ▼=pour tubes avec paroi de 1,5 mm d'épaisseur

d=tube outside diameter  
 e=minimum bore  
 L=installed length  
 ▼=for tubes with wall thickness of 1,5 mm

**T-Verschraubung**

mit Übergangsmuffe

**Té**

avec adaptateur femelle

**Tee union**

with female adaptor

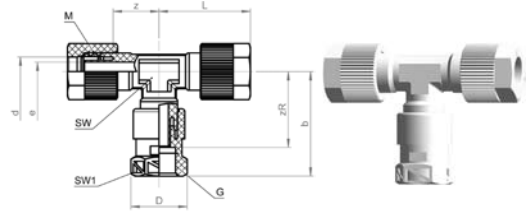
**SO 23221**

Type - d - G	Mat.-Nr.	bar	M	SW	SW1	L	b	D	zR	z	e	kg/100
G= Rohrgewinde (zylindrisch)	G= Filetage-gaz BSP (cylindrique)	G=BSP thread (straight)										
SO 23221-4-1/8-4	128.3201.060	10	10 x 1	12	14	24.5	36.0	16.0	27.0	13.5	3.1	1.280
SO 23221-4-1/4-4	128.3201.065	10	10 x 1	12	17	24.5	37.0	22.0	27.0	13.5	3.1	1.420
SO 23221-6-1/8-6	128.3201.100	10	10 x 1	12	14	24.5	36.0	16.0	27.0	13.5	3.1	1.240
SO 23221-6-1/4-6	128.3201.110	10	10 x 1	12	17	24.5	37.0	22.0	27.0	13.5	3.1	1.380
SO 23221-8-1/4-8	128.3201.170	10	12 x 1	14	17	29.0	39.0	22.0	29.0	17.0	5.1	1.930
SO 23221-10-1/4-10	128.3201.270	10	14 x 1	17	19	32.5	38.5	22.0	28.5	18.5	6.7	2.810
SO 23221-10-3/8-10	128.3201.280	10	14 x 1	17	22	32.5	44.0	25.5	33.0	18.5	6.7	3.290
▼ SO 23221-10/7-1/4-10/7	128.3201.320	10	14 x 1	17	19	32.5	38.5	22.0	28.5	18.5	5.2	2.640
▼ SO 23221-10/7-3/8-10/7	128.3201.330	10	14 x 1	17	22	32.5	44.0	25.5	33.0	18.5	5.2	3.120
SO 23221-12-3/8-12	128.3201.390	10	16 x 1	19	22	34.0	44.5	25.5	33.5	17.5	7.2	4.040
SO 23221-12-1/2-12	128.3201.400	10	16 x 1	19	27	34.0	48.5	30.5	34.5	17.5	7.2	4.670
▼ SO 23221-12/9-3/8-12/9	128.3201.412	10	16 x 1	19	22	34.0	44.5	25.5	33.5	17.5	7.2	4.020
▼ SO 23221-12/9-1/2-12/9	128.3201.414	10	16 x 1	19	27	34.0	48.5	30.5	34.5	17.5	7.2	4.650
▼ SO 23221-16/13-3/8-16/13	128.3201.564	10	22 x 1,5	24	27	50.5	61.5	30.6	50.5	28.0	11.0	8.000
▼ SO 23221-16/13-1/2-16/13	128.3201.566	10	22 x 1,5	24	27	50.5	61.5	30.6	47.5	28.0	11.0	8.200
▼ SO 23221-16/13-3/4-16/13	128.3201.568	10	22 x 1,5	24	32	50.5	61.5	36.6	46.5	28.0	11.0	8.600

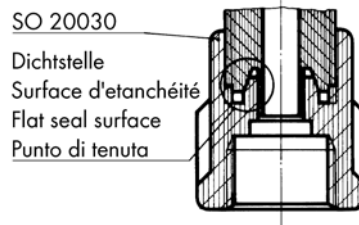
**Anwendungsbeispiele:**
**Exemples d'utilisation:**
**Sample combinations:**

Die Übergangsmuffe SO 20030 ist lose aufgeschraubt und kann mit der Rändelmutter SO 20020 gewechselt werden. Beim Anziehen dichtet die angedrehte Dichtkante ab.

Kombinationsbeispiele siehe SO 20030

Weitere Verschraubungen mit Innengewinde siehe SO 21221 und SO 22221.

L'adaptateur femelle SO 20030 est monté librement. Lors du serrage, l'arête d'étanchéité forme un joint parfait.

Exemples d'utilisation voir SO 20030

Autres raccords avec adaptateur femelle, voir SO 21221 et SO 22221.

The female adaptor SO 20030 is screwed on loosely and can be exchanged with the knurled nut SO 20020. The integrally turned sealing lip produces a seal on being tightened.

Sample combinations see SO 20030

Alternative unions with female adaptor see SO 21221 and SO 22221.

d=Rohrassen-ø  
e= kleinste Bohrung  
L= Mass in montiertem Zustand  
▼=für Rohre mit Wandung 1,5 mm

d=ø extérieur du tube  
e= ø-min. de passage  
L=après montage  
▼=pour tubes avec paroi de 1,5 mm d'épaisseur

d=tube outside diameter  
e=minimum bore  
L=installed length  
▼=for tubes with wall thickness of 1,5 mm

**Einstell-T**  
**Té orientable**  
**Adjustable tee union**

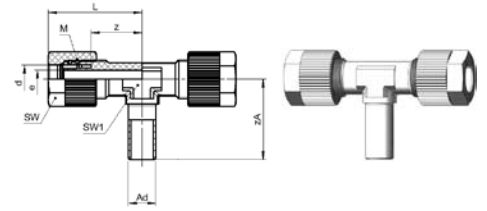

**SO 23621**

Type -d -Ad -d	Mat.-Nr.	bar	M	SW	SW1	L	f	zA	z	e	kg/100
SO 23621-6-A6-6	128.3600.060	10	10x1	12	8	25.0	14.0	24.0	14.0	2.8	0.880
SO 23621-8-A8-8	128.3600.080	10	12x1	14	10	26.5	16.0	25.0	14.5	4.8	1.190
SO 23621-10-A10-10	128.3600.100	10	14x1	17	12	30.0	20.0	29.0	16.0	6.6	1.830
SO 23621-12-A12-12	128.3600.120	10	16x1	19	13	32.5	21.0	30.0	16.0	8.0	2.395

2

**Anwendungsbeispiele:**

**Exemples d'utilisation:**

**Sample combinations:**

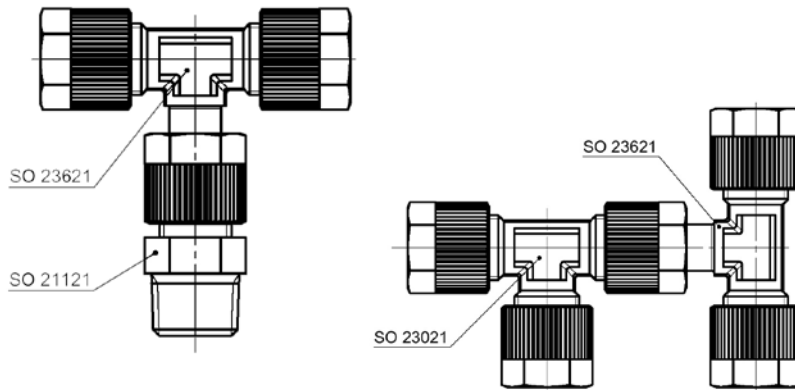

d=Rohraussen-ø  
 Ad=Aussen-ø der Andrehung  
 e=kleinste Bohrung  
 L=Mass in montiertem Zustand

d=ø extérieur du tube  
 Ad=ø extérieur de la portée cylindrique  
 e=ø-min. de passage  
 L=après montage

d=tube outside diameter  
 Ad=outside diameter of cyl. Stub  
 e=minimum bore  
 L=installed length

**T-Einschraubverschraubung**

**Té mâle**

**Male adaptor tee union**

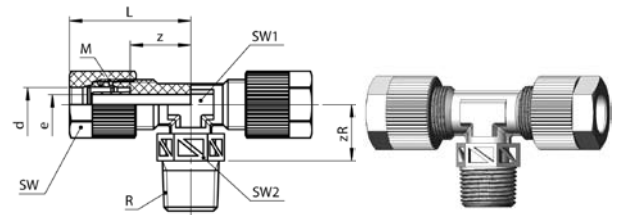

**SO 23721**

Type -d -R -d	Mat.-Nr.	bar	M	SW	SW1	SW2	L	zR	z	e	kg/100
R= Rohrgewinde (kegelig)	R= Filetage-gaz BSP (conique)	R=BSP thread (tapered)									
SO 23721-4-1/8-4	128.3701.040	10	10 x 1	12	10	10	25.0	11.0	14.0	2.8	0.926
SO 23721-4-1/4-4	128.3701.045	10	10 x 1	12	14	14	25.0	12.5	14.0	2.8	1.148
SO 23721-6-1/8-6	128.3701.100	10	10 x 1	12	10	10	25.0	11.0	14.0	2.8	0.938
SO 23721-6-1/4-6	128.3701.110	10	10 x 1	12	14	14	25.0	12.5	14.0	2.8	1.160
SO 23721-8-1/8-8	128.3701.160	10	12 x 1	14	10	10	26.5	12.0	14.5	4.8	1.197
SO 23721-8-1/4-8	128.3701.170	10	12 x 1	14	10	14	26.5	13.5	14.5	4.8	1.300
SO 23721-10-1/4-10	128.3701.270	10	14 x 1	17	14	14	30.0	14.5	16.0	6.6	2.058
SO 23721-10-3/8-10	128.3701.280	10	14 x 1	17	17	17	30.0	15.0	16.0	6.6	1.720
▼ SO 23721-10/7-1/4-10/7	128.3701.320	10	14 x 1	17	14	14	30.0	14.5	16.0	5.6	1.544
▼ SO 23721-10/7-3/8-10/7	128.3701.330	10	14 x 1	17	17	17	30.0	15.0	16.0	5.6	1.762

Zum Abdichten der Einschraubgewinde empfehlen wir Teflonband.

Pour assurer l'étanchéité des filetages mâles, nous recommandons le téflon en bande.

For sealing the adaptor threads we recommend teflon tape.

Reduktionen siehe SO 21821

Réductions voir SO 21821

Reductions please see SO 21821

d=Rohrassen-ø  
 e= kleinste Bohrung  
 L= Mass in montiertem Zustand  
 ▼=für Rohre mit Wandung 1,5 mm

d=ø extérieur du tube  
 e= ø-min. de passage  
 L=après montage  
 ▼=pour tubes avec paroi de 1,5 mm d'épaisseur

d=tube outside diameter  
 e=minimum bore  
 L=installed length  
 ▼=for tubes with wall thickness of 1,5 mm

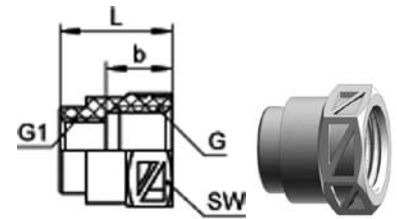
**Reduziermuffe**
**Réduction femelle-femelle**
**Female reduction socket**

**SO 20031**

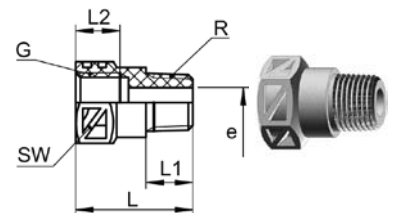
Type -G-G1	Mat.-Nr.	bar	SW	L	b	kg/100
G= Rohrgewinde (zylindrisch)	G= Filetage-gaz BSP (cylindrique)	G=BSP thread (straight)				
G1= Rohrgewinde (zylindrisch)	G1= Filetage-gaz BSP (cylindrique)	G1=BSP thread (straight)				
SO 20031-1/8-1/8	126.0311.042	10	14	16.0	8.0	0.199
SO 20031-1/8-1/4	126.0311.044	10	17	17.0	11.0	0.323
SO 20031-1/8-3/8	126.0311.046	10	22	18.0	12.0	0.546
SO 20031-1/8-1/2	126.0311.048	10	27	21.0	14.0	1.081
SO 20031-1/4-1/4	126.0311.104	10	17	17.5	9.0	0.331
SO 20031-1/4-3/8	126.0311.106	10	22	19.0	12.0	0.568
SO 20031-1/4-1/2	126.0311.108	10	27	22.0	14.0	1.083
SO 20031-3/8-3/8	126.0311.166	10	22	19.0	9.5	0.558
SO 20031-3/8-1/2	126.0311.168	10	27	22.5	14.0	1.081

**Reduziernippel**
**Réduction femelle-mâle**
**Male reduction nipple**

**SO 20041**

Type -G-R	Mat.-Nr.	bar	SW	L	L1	L2	kg/100
G= Rohrgewinde (zylindrisch)	G= Filetage-gaz BSP (cylindrique)	G=BSP thread (straight)					
R= Rohrgewinde (kegelig)	R= Filetage-gaz BSP (conique)	R=BSP thread (tapered)					
SO 20041-1/8-1/8	126.0411.042	10	14	20.0	8.0	7.0	0.242
SO 20041-1/8-1/4	126.0411.044	10	14	24.0	12.0	7.0	0.327
SO 20041-1/8-3/8	126.0411.046	10	17	25.0	12.0	7.0	0.701
SO 20041-1/8-1/2	126.0411.048	10	22	30.0	16.0	7.0	1.154
SO 20041-1/4-1/8	126.0411.102	10	17	21.0	8.0	8.0	0.363
SO 20041-1/4-1/4	126.0411.104	10	17	25.0	12.0	8.0	0.515
SO 20041-1/4-3/8	126.0411.106	10	17	25.0	12.0	8.0	0.497
SO 20041-1/4-1/2	126.0411.108	10	22	30.0	16.0	8.0	1.106
SO 20041-3/8-1/4	126.0411.164	10	22	26.0	12.0	8.5	0.731
SO 20041-3/8-3/8	126.0411.166	10	22	26.0	12.0	8.5	0.862
SO 20041-3/8-1/2	126.0411.168	10	22	30.0	16.0	8.5	0.916

## Sechskant-Verschlussschraube

### Bouchon mâle à 6 pans

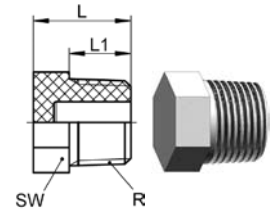
### Male hexagon plug



#### SO 20371

Type -R	Mat.-Nr.	SW	L	L1	kg/100
R= Rohrgewinde (kegelig)	R= Filetage-gaz BSP (conique)			R=BSP thread (tapered)	
SO 20371-1/8	126.0721.020	10	13.0	8.0	0.141
SO 20371-1/4	126.0721.040	14	18.5	12.0	0.379
SO 20371-3/8	126.0721.060	17	19.0	12.0	0.356
SO 20371-1/2	126.0721.080	22	24.0	16.0	1.810

## Einschraubtülle

### Douille cannelée à visser

### Male adaptor hose nozzle

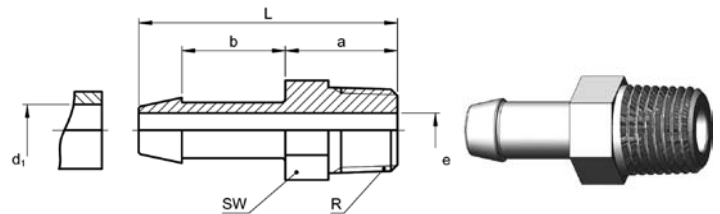

#### SO 20511

Type -d1 -R	Mat.-Nr.	bar	SW	L	a	b	e	kg/100
R= Rohrgewinde (kegelig)	R= Filetage-gaz BSP (conique)							
								R=BSP thread (tapered)
SO 20511-4-1/8	126.0511.060	10	10	24.0	13.0	8.0	3.0	0.157
SO 20511-6-1/8	126.0511.100	10	10	30.0	13.0	12.0	4.0	0.201
SO 20511-6-1/4	126.0511.110	10	14	35.5	18.5	12.0	4.0	0.438
SO 20511-8-1/4	126.0511.170	10	14	35.5	18.5	12.0	6.0	0.456
SO 20511-10-3/8	126.0511.280	10	17	38.0	19.0	14.0	7.0	0.764
SO 20511-12-3/8	126.0511.390	10	17	38.0	19.0	14.0	10.0	0.649
SO 20511-12-1/2	126.0511.400	10	22	43.0	24.0	14.0	10.0	1.262

Für die Schlauchsicherung verwenden Sie bitte unsere Schlauchklemme SO 40512 (Stahl promatverzinkt).

d1 = Schlauchinnen-Ø  
e = kleinste Bohrung

Afin d'assurer la bonne tenue des tuyaux, utiliser nos colliers de serrage SO 40512 (Acier zingué passivé).

d1 = Ø intérieur du tuyau  
e = Ø min. de passage

Please use our hose clip SO 40512 (zinc promatised) for securing the hose.

d1 = hose inside diameter  
e = minimum bore

**Doppelnippel konisch-konisch**  
**Mamelon mâle-mâle conique-conique**  
**Male adaptor tapered-tapered**

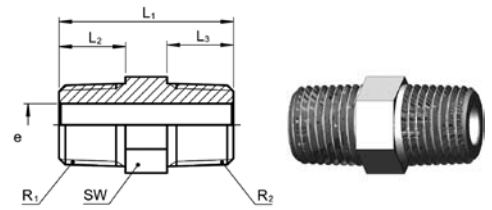
**SO 21109**

Type -R1 -R2	Mat.-Nr.	SW	L1	L2	L3	e	kg/100
R= Rohrgewinde (kegelig)	R= Filetage-gaz BSP (conique)	R=BSP thread (tapered)					
SO 21109-1/8k - 1/8k	126.0641.042	10	21.0	8.0	8.0	5.1	0.208
SO 21109-1/8k - 1/4k	126.0641.044	14	26.5	8.0	12.0	5.1	0.449
SO 21109-1/4k - 1/4k	126.0641.104	14	30.5	12.0	12.0	6.7	0.577
SO 21109-1/4k - 3/8k	126.0641.106	17	31.0	12.0	12.0	6.7	0.817
SO 21109-1/4k - 1/2k	126.0641.108	22	36.0	12.0	16.0	6.7	1.359
SO 21109-3/8k - 3/8k	126.0641.166	17	30.0	12.0	12.0	8.0	0.935
SO 21109-3/8k - 1/2k	126.0641.168	22	36.0	12.0	16.0	8.0	1.489
SO 21109-1/2k - 1/2k	126.0641.228	22	40.0	16.0	16.0	12.0	1.727
SO 21109-1/2k - 3/4k	126.0641.232	27	40.5	16.0	16.5	12.0	2.277